



 **CONCRETE CANVAS®**
Concrete on a Roll

INSTALLATION GUIDE: CHANNEL LINING



RAIL



ROAD



MINING



PETROCHEM



AGRO



PUBLIC WORKS



UTILITIES



DEFENCE



DESIGN



SHELTER

1.0 General

Concrete Canvas® (CC) is the original Geosynthetic Cementitious Composite Mat (GCCM) and the first product to declare conformance to ASTM D8364 'Standard Specification for GCCMs'. It is a flexible, concrete filled geotextile that hardens on hydration to form a thin, durable and waterproof concrete layer. Essentially, it can be described as *Concrete on a Roll*™ and is used for a wide variety of applications including the rapid lining of drainage channels, providing slope protection, weed suppression, culvert repair and general concrete remediation.

This document provides general guidance procedures for the installation of CC as channel lining in a manner that maximises safety, efficiency, and the physical integrity of the material and channel.

- This installation guidance should be read in conjunction with the construction drawings taking account of the designer's project specifications. Consult the [CC Specification Guide: Watercourses](#) for detailed installation advice.
- The versatile nature of CC means that this document is not exhaustive and is intended for guidance purposes only. Exceptions to this guideline may be required to address site-specific conditions.
- The performance of the CC is wholly dependent on the quality of its design and installation. It is the installer's responsibility to adhere to these guidelines where applicable and to the project specification and construction drawings.

2.0 Equipment Required

- Sufficient CC to complete the project including allowance for edge fixings and overlaps
- Suitable lifting equipment to dispense CC Bulk or Wide Rolls
- Safety mask and gloves
- Cutting equipment, snap off knife or disc cutter
- Metal or plastic fixing pins
- Lump hammer
- Screwdriver and stainless steel screws or alternative approved method to join the CC layers
- Water supply
- See the [CC Equipment List](#) for full details.
- For ordering, offloading and storage information, see the [CC Logistics Guide](#) for full details.
- Dust hazard. Wear appropriate PPE. Consult [CC SDS](#) document.

3.0 Substrate Preparation

Divert water (if lining an existing watercourse). Remove vegetation and grade channel to a uniform profile to suit the design dimensions.

Remove sharp or protruding rocks >25mm and fill large voids. If the perimeter edge of the CC is terminating in a soil substrate (i.e. it is not going to be connected to existing infrastructure), excavate crest anchor trenches into the shoulders of the channel. Excavate Leading and Trailing edge anchor trenches on side slopes and along the invert. Anchor trench dimensions must be a minimum of 150mm x 150mm but may need to be increased to suit the designer's requirements.

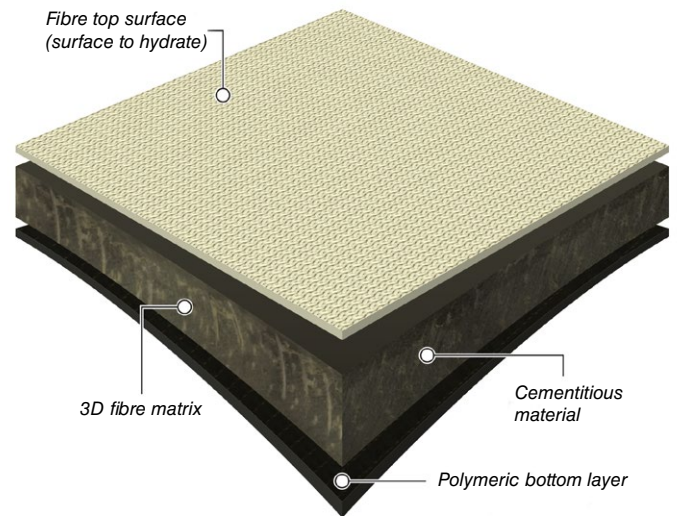

Typical CC cross section



Equipment required



Substrate preparation & anchor trench

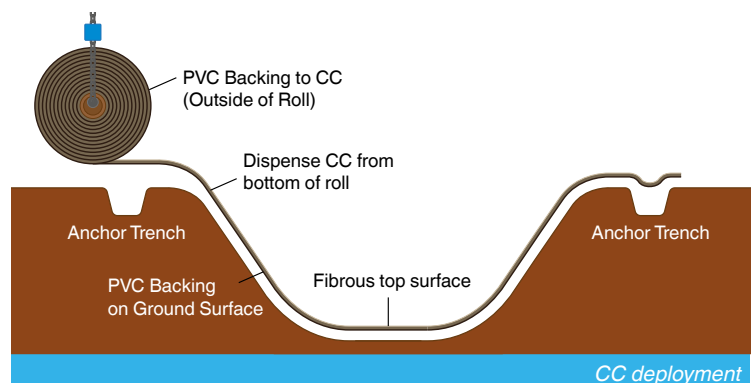

CC deployment

Consult the construction drawings to verify if special substrate preparation measures such as minimum bearing capacity requirements, installation of a non-woven geotextile, or if substrate drainage details are needed.

4.0 Deployment

CC must be placed to ensure direct contact with the surface to prevent void space. Begin at downstream end of channel and work up gradient.

Remove packaging (making sure to note the Roll ID) and unroll CC in channel profile to suit specified layup (longitudinal or transverse layup as specified on the design drawings), ensuring the fibrous top surface faces upwards, with the PVC membrane in contact with the ground. This is achieved by dispensing the roll by naturally unrolling along the ground rather than pulling material from the top. Avoid snagging the CC on the substrate. It is important to relax the material to relieve any tension generated in deployment. This can be achieved by lifting the CC layer by hand and repositioning. The installer can adjust the material to remove any wrinkles and ensure the CC conforms to the substrate when hand repositioning.

Personnel must not wear damaging shoes and avoid walking on the CC surface to prevent staining, particularly with wet footwear prior to hydration. On restricted access projects where installers have no option but to walk on CC, the surface can be protected by using timber boards to prevent boots from creating depressions in the material.

For transverse layup installations, tuck the edge of the CC into the anchor trench before cutting to length. When cutting unset CC, a 15-20mm allowance should be left from the cut edge due to potential loss of fill. If cutting with a disc cutter, it is recommended to wet the cut beforehand to minimise dust generation.

Ensure the trailing edge of the first layer of CC is either suitably terminated into existing infrastructure and fixed to prevent water ingress (e.g. using stainless steel clamping bar and gasket), or tucked into an anchor trench which is backfilled to prevent scour beneath CC.

When positioning subsequent layers, ensure there is at least a 100mm overlap in the direction of water flow (shingled like roof tiles) and that the material layers are in intimate contact with each other.

5.0 Jointing

Verify the specified joint method to be installed.

5.1 For Screwed / Screwed and Sealed joints:

- Fold back top layer and hydrate the material under the overlapped sections of the CC. This is important to ensure the joint cures to optimum strength. Once hydrated, the material remains workable for 1 to 2 hours
- If applying a CC approved sealant, apply an 8mm diameter continuous bead along the line of where the screws will be positioned (eg. for a 100mm overlap with screws 30mm from the edge of the top layer, the sealant bead needs to be 70mm from the edge of the bottom layer)

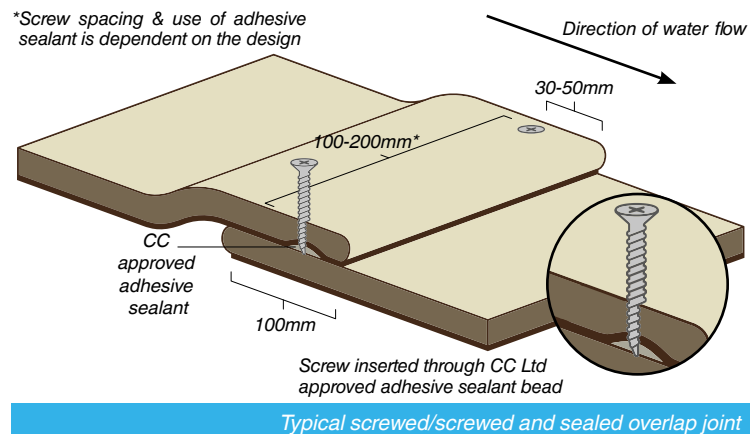

- Fold the top layer back into position and insert stainless screws at the specified centres (eg 100mm, 200mm, 100mm Zigzag), at the specified distance from the edge of the CC (eg 30mm, 50mm, 15mm & 50mm)

5.2 For Thermal Bond joints:

- Ensure CC remains dry and unhydrated before jointing
- Follow the *CC User Guide: Thermal Bonding* for the correct procedure.

Ensure there is no rucking at the joint and both layers are in contact with each other. Care shall be taken during installation to avoid damage occurring to the CC. Should the CC be damaged during installation and before hydration, the layer should be removed and replaced.

6.0 Perimeter Edge Fixing

It is essential that all exposed (i.e. unjointed) edges of the CC should be secured during the installation to prevent water ingress underneath the CC which may cause wash-out of the substrate and subsequent undermining.

6.1 When fixing to Soil (i.e. using anchor trenches):

- Position the CC over the shoulder of the channel and into the anchor trench.
- Fix the CC in the anchor trench by inserting fixing pegs through each overlap or at a minimum of 2m intervals for longitudinal installations.
- The CC should be hydrated before backfilling with non-erodible fill. This may be soil or concrete depending on the design. Consult the construction drawings.

6.2 When fixing to Concrete/Masonry/Rock:

- Consult the construction drawings for the mechanical fixing specifications and fixing spacings.
- Position the CC against the structure and drill a pilot hole through the CC and the structure before inserting the mechanical fixing.
- Use appropriate sealant/gasket and washers/clamping bar as specified by the designer to ensure a strong, watertight seal.

Ensure the leading edge of the final layer of CC is either suitably terminated into existing infrastructure and fixed to prevent water ingress (e.g. using stainless steel clamping bar and gasket), or tucked into an anchor trench which is backfilled to prevent scour beneath CC.

7.0 Intermediate Fixings

Additional intermediate fixings may be necessary to profile CC on uneven substrates to ensure it conforms to the underlying surface and remove voids, or to resist the following load conditions:

- Hydraulic Shear Loads: e.g. lining channels with an incline >10%
- Wind Loads: e.g. in exposed locations where slope lengths exceed 7m
- Warmer Climate Detailing: e.g. where CC profile lengths exceed 3m

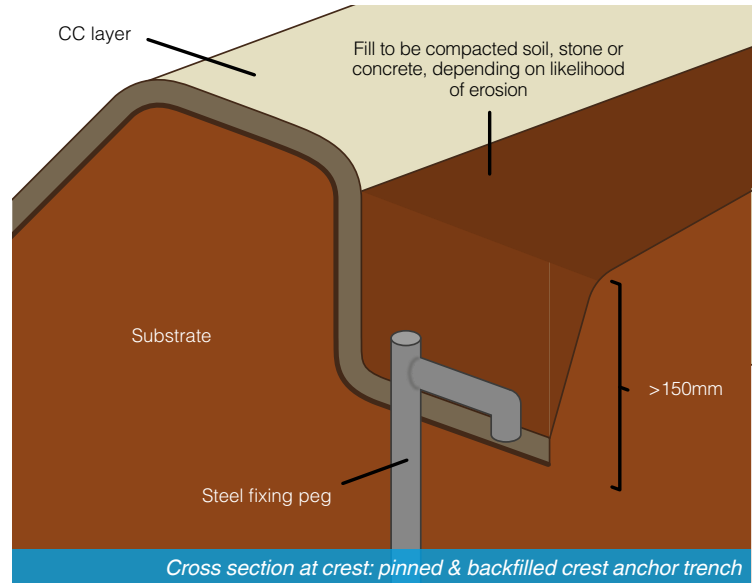

Cross section at crest: pinned & backfilled crest anchor trench

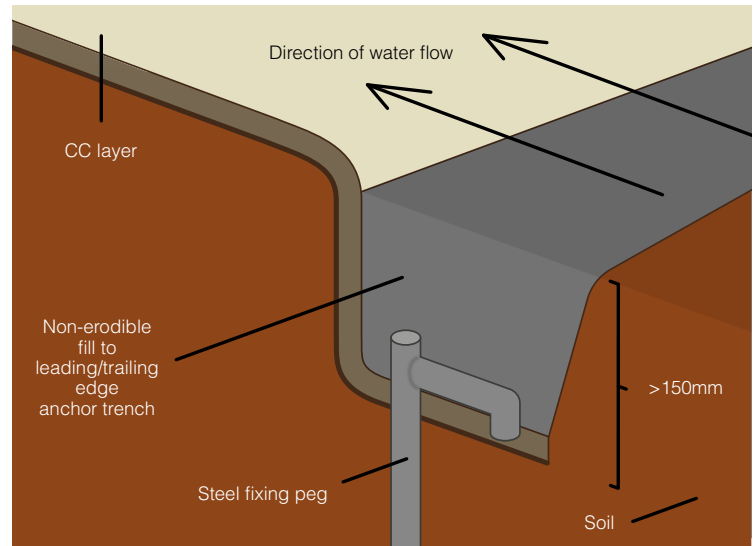

Cross section at invert edge: leading/trailing edge anchor trench detail

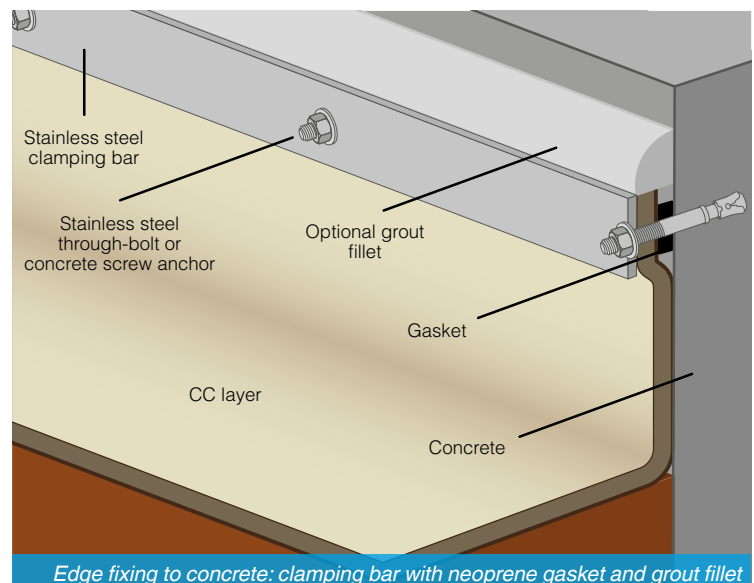

Edge fixing to concrete: clamping bar with neoprene gasket and grout fillet

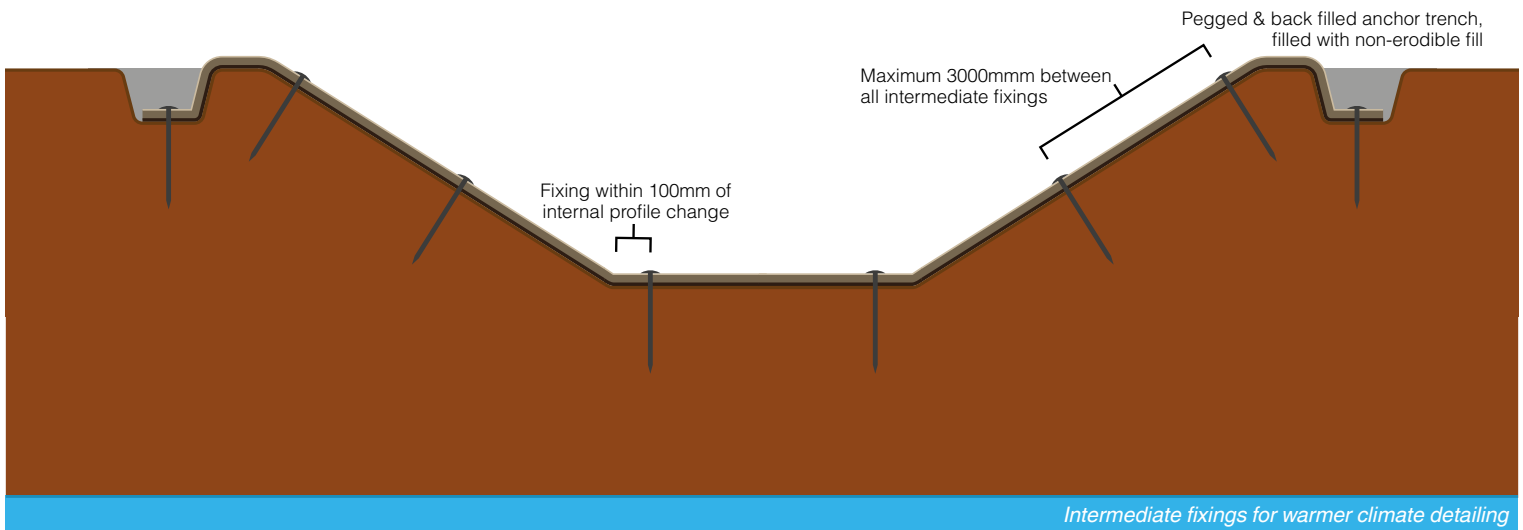

Intermediate fixings for warmer climate detailing

The intermediate fixing type, performance requirements and installation locations should be specified by the designer to suit the anticipated load conditions. 'round head' fixing pegs are typically used for profiling and warmer climate detailing. When a greater head plate diameter or pull-out strength is required, for example when designing to resist hydraulic shear or wind uplift, larger intermediate fixings such as Earth Percussion Anchors may be specified. Mid-channel anchor trenches (known as check slots) may also be required by the designer, or incorporated into large installations at the end of the working day to prevent scour and undermining of the CC before returning to continue the installation. Consult the construction drawings.

8.0 Bespoke Detailing

Consult the construction drawings for bespoke detailing such as baffling, accommodating pipe penetrations and junctions. Concrete Canvas Ltd can provide advice on unforeseen bespoke details.

9.0 Hydration

If necessary, the Installer must place temporary ballast, such as sandbags, on top of the laid CC prior to hydration to prevent wind uplift and ensure that it lies flat to the substrate on undulating ground to prevent voids from forming underneath the material.

After fixing and jointing, the surface of the CC can be brushed clean to remove marks and debris before spraying with water to hydrate.

Spray the fibre surface multiple times until the CC is fully saturated. The wet CC will first darken and then become lighter as it absorbs the water.

Do not spray high pressure water directly onto the CC as this may wash a channel in the material.

CC can be hydrated using fresh water or salt water, it is not possible to over hydrate CC and it will hydrate and set underwater.

A minimum volume of water equal to 50% of the material weight is required. For example, CC8 requires 6 litres of water per square meter.

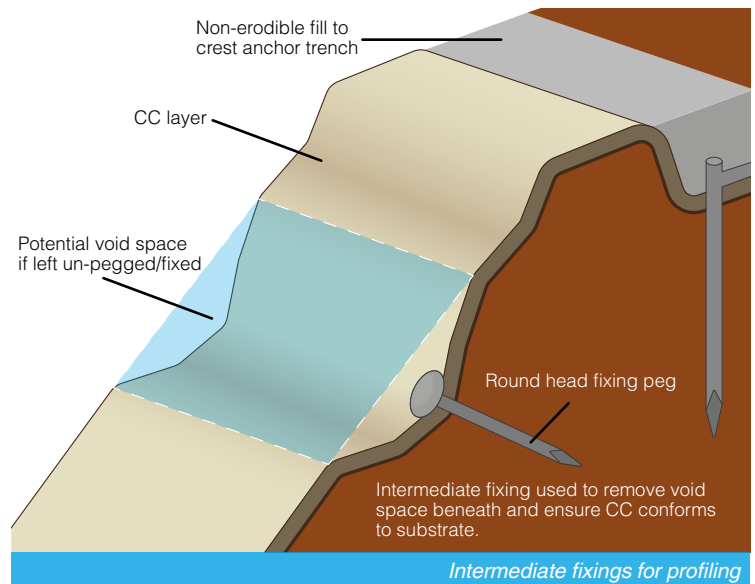

Intermediate fixings for profiling

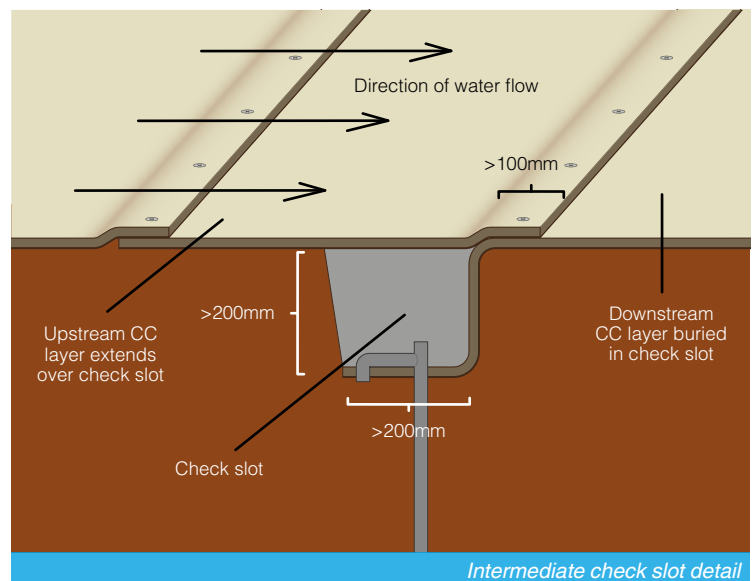

Intermediate check slot detail

To check proper hydration, the CC should feel wet to the touch several minutes after hydration. Press your thumb into the CC and release. If water is present in the depression in the CC, it has been sufficiently hydrated. If no water is observed, then more water must be applied.

Specific hydration methods are required in drying conditions (installing in high air temperatures (>22°C), wind (>12km/h), strong direct sunlight or low humidity (<70%)) and in low temperature conditions. Please consult the [CC User Guide: Hydration](#) which is also attached on all CC Bulk rolls.

It is not recommended to rely on rainfall to provide hydration.

10.0 Setting

There is a working time of 1-2 hours after hydration.

Backfill anchor trenches with non-erodible fill as specified in the construction drawings to create a neat termination and encourage surface water runoff to flow over the anchor trench and in to the CC channel.

CC hardens to strength in 24 hours and is then ready for use.

Allow the CC to cure for at least 48 hours before applying any post installation surface treatments such as jet washing or painting.

11.0 Installation Sequence

Planning of CC installations is necessary to ensure tools and materials (e.g. hydration water) is available when required.

Only install what can be fully jointed, fixed and hydrated before the end of construction day to minimise any adverse effect on the installation and/or performance capabilities of the product.

If installation continues the following working day, protect the edge of the last layer of CC overnight with waterproof sheeting to enable jointing on return to work. Alternatively install check slots.

An example install sequence is described below:

- Morning - Deploy CC panels and secure along the perimeter edges.
- Early afternoon - Jointing of panels (e.g. hydrate under-lap, apply sealant, screw joints), install intermediate fixings.
- Late afternoon - Hydration (following drying/low temperature condition guidance as required).

12.0 Maintenance and Repair

For the majority of projects, CC does not require cleaning or maintenance unless structures such as silt traps are installed. If required, consult the [CC User Guide: Cleaning and Maintenance](#). If damage is found during a periodic inspection, contact Concrete Canvas Ltd for repair advice.

Concrete Canvas Ltd and its Sales Partner distribution network can provide manufacturers recommendations for specific projects, but before installing all details must be agreed and adopted by the engineer under their design responsibility.



Hydration



Hydration touch test



Ensure adequate hydration, do not rely on rainfall



Backfill anchor trench